

TILT-LOCK™

SIDE MOUNT SPIGOT (SSSPIGOTSIDE) INSTALLATION INSTRUCTIONS

STEP #1:

Mark position of holes to be drilled and drill holes.

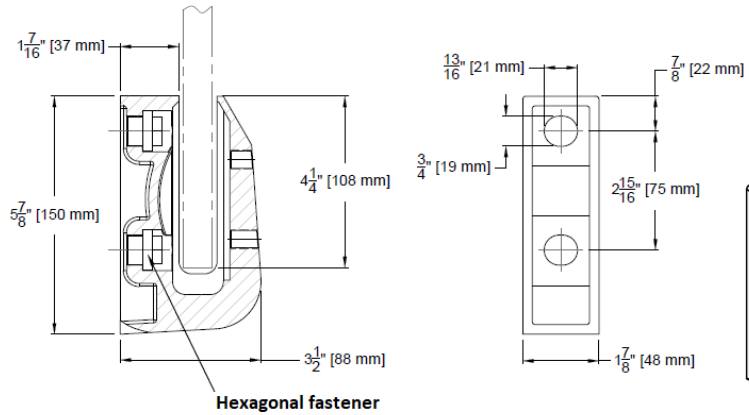
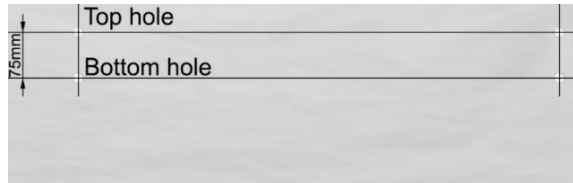

STEP #2:

The fasteners should be inserted and protrude from the wall between 14-16mm to ensure that the hexagonal fasteners in STEP #3 will fully engage.

Ensure that fasteners are in alignment.

Hexagonal fastener is imperial 1/2"-13 threaded. Make sure correct fasteners are ordered to match threads on hexagonal fasteners of spigot.

Additional hexagonal fastener is available and sold separately. # SSSPIGOTSIDI (1/2"-13)

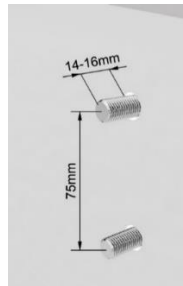

FASTENING OPTIONS:

- *For wood, use hanger bolts (or threaded rods if accessible from behind).
- *For concrete, use wedge anchors.

STEP #3:

When the fasteners are secured, fit the side mounts over the fasteners.

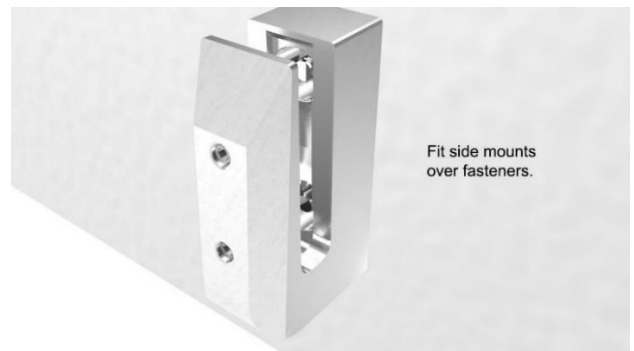
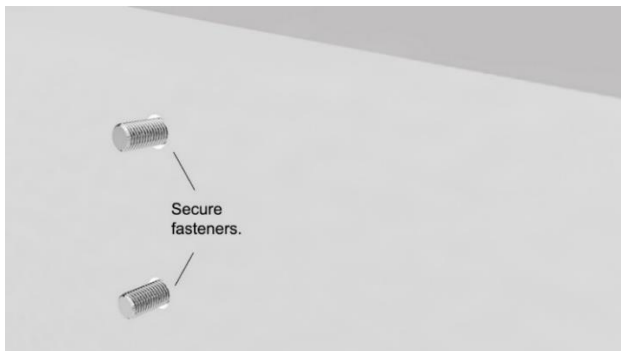

STEP #4:

1) Turn hexagonal fasteners (see picture below) onto fasteners by hand initially until there is sufficient room to allow the socket tool (**SSSPIGOTSIDT**) to fit inside the side mount to tighten.
(SSSPIGOTSIDT not included in box.)

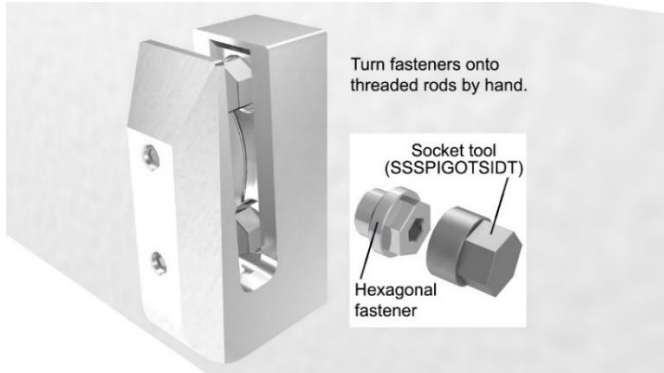

2) Use a 19mm (3/4") spanner or wrench (**SSWRENCH1**) to tighten hexagonal fasteners completely.

Alternatively, use a shortened Allen key (cut down to maximum 22mm width) to tighten hexagonal fasteners completely.

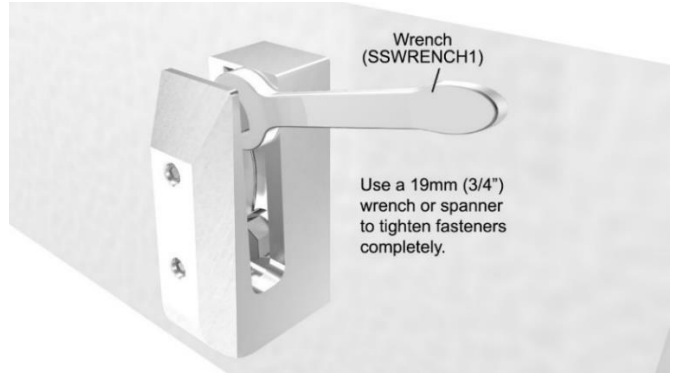

STEP #5:

Install the L-Plate, followed by the I-Plate.



STEP #6:

Install the L-Gasket, followed by the I-Gasket. Set up glass. Choose the gaskets to suit glass size. Refer to Gaskets Legend below.



Gaskets Legend

Glass Size	Gasket Sticker Colours	
12-13.5mm	Yellow L-Gasket +	Red I-Gasket
13.5-15mm	Yellow L-Gasket +	White I-Gasket
15-16mm	Green L-Gasket +	Red I-Gasket
16-17.52mm	Green L-Gasket +	White I-Gasket

STEP #7:

TILT-LOCK™ Tightening & Adjustment

Align the glass by adjusting the upper and lower screws.

Tighten the upper screw and loosen the lower screw to tilt the glass backward. Do the reverse to tilt the glass forward. Up to 2° of adjustment is possible.

