

SCREW FIXED GATE CLOSING STRUT

- Top quality gate closing strut, ideal for closing gates up to 180lb.
- Using the unique adjustable brackets the force this closer exerts can be altered as required.
- No need to release gas, simply move the strut along the slots in the brackets to adjust the force exerted. The force can be increased again by moving the strut further than the gate hinge.
- The adjustable brackets also make the installation easy as there is no need to compress the spring when fitting it to the gate.



PRODUCT DETAILS

Product code:	Description:
GSBW	Screw fixed gate closing strut
Max gate weight:	180lb
Max gate size:	8' 2" high x 4' wide
End fittings:	M10 elbow joints Fitted with steel rod protection tube.
Finish:	Black finish
Center to center:	2' 7-3/16"
Stroke length:	9-7/16"
Force:	300N

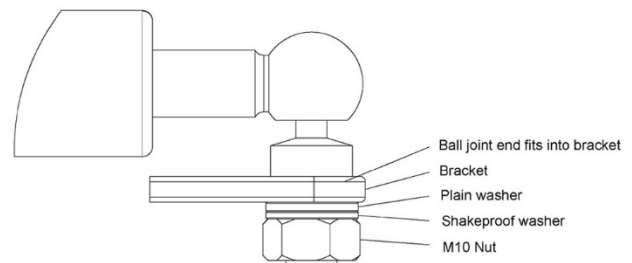

INSTALLATION

1. Screw the brackets supplied in position relative to the center of the hinge as shown.
2. Close the gate and secure the strut to the slotted bracket and the long bracket using the shakeproof washers and nuts provided. Washers position are as shown. To increase or decrease the force exerted on the gate, reposition the strut on the long bracket as required.
3. **MAINTENANCE** The piston rod is protected by a steel cover tube. The piston rod should not be lubricated or damaged in any way, as this will reduce the life of the seals. Periodically lubricate the ball joints with a light oil and clean the surface of the gas strut with a damp cloth.

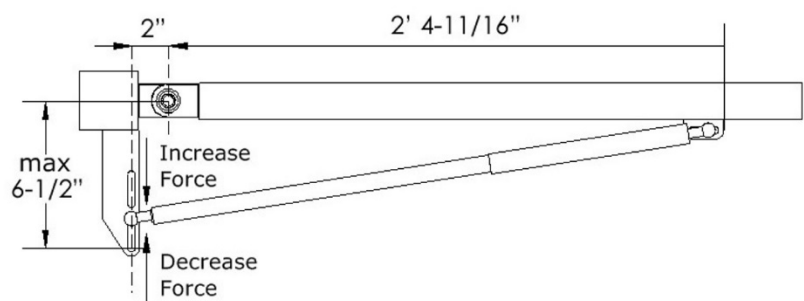

euro ARCHITECTURAL COMPONENTS

VISIT OUR WEBSITE FOR MORE INFORMATION.
CONTACT US FOR INQUIRIES.

