

- Stainless steel latchbolt which springs 1/2" into the gate post and then moves 1-1/8" when the key is turned to deadlock the lock.
- Latchbolt is adjustable in length for precise fitting on site.
- Easy to rotate latchbolt for LH/RH gates.
- Supplied with handles.
- Supplied with bolt guide plate and gate post strike plate.



## PRODUCT OPTIONS

Two locks available,

- SBLD1601** To fit 1/2" - 1-1/4" gate frame  
**SBLD1602** To fit 1-1/2" - 2-1/4" gate frame



## INSTALLATION

1. Drill 2 x 3/8" dia. holes at 3-5/8" centres for M8 fixing bolts
2. Drill 3/4" clearance hole for latchbolt at 7/8" centres down from the top 3/8" hole
3. Fix lock in place using stainless steel clamp plate, bolt support plate and 2 stainless steel countersunk fixing bolts supplied.
4. Drill clearance hole in keep or outer frame to receive the latchbolt. Slot this hole vertically to allow for gate sag.
5. Ensure latchbolt moves freely without binding on gate or frame.

## MAINTENANCE

Every 2 months - Lubricate latchbolt with light oil.  
Annually - Dismantle lock and spray mechanism inside with light oil.

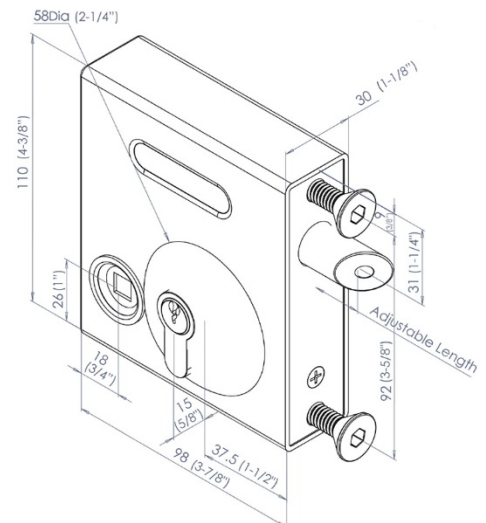

VISIT OUR WEBSITE FOR MORE INFORMATION.  
CONTACT US FOR INQUIRIES.

