

# Installation Instructions

## Top Mount Base Shoe - Aluminum Cladding

SSSM3SHOE10A (10 ft.)  
SSSM3SHOE20A (20 ft.)



The kit includes the following components:

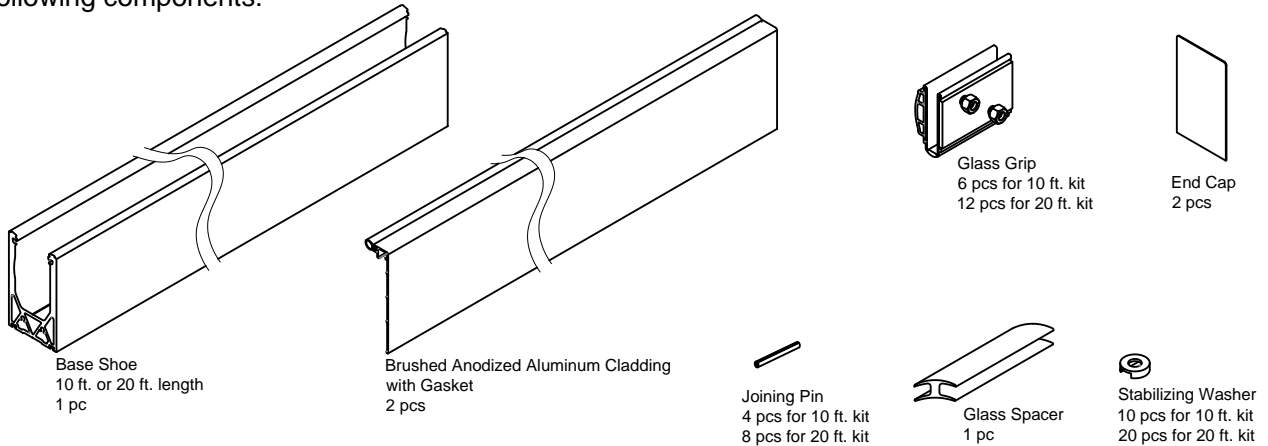

1

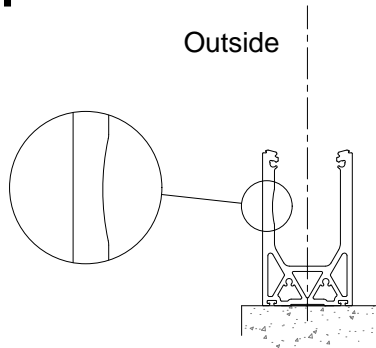

Make sure that the curved side of the Base Shoe is facing the outside.

2

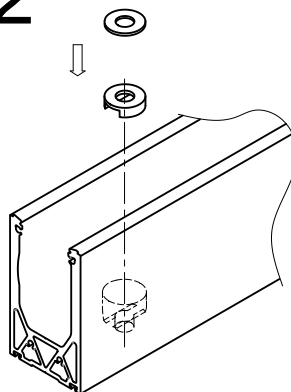

Put the Stabilizing Washer in place by aligning the slot with the ribs at the bottom of the base shoe. To secure the base shoe, ensure that you use a flat washer with suitable fasteners.

3

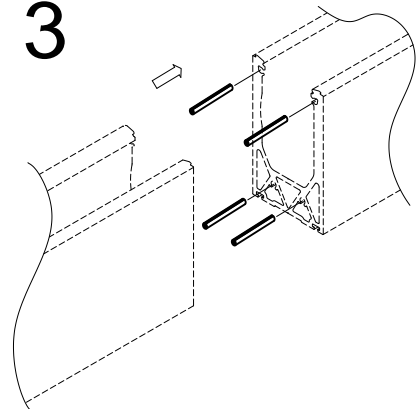

Use the Joining Pins to connect the shoes.

4

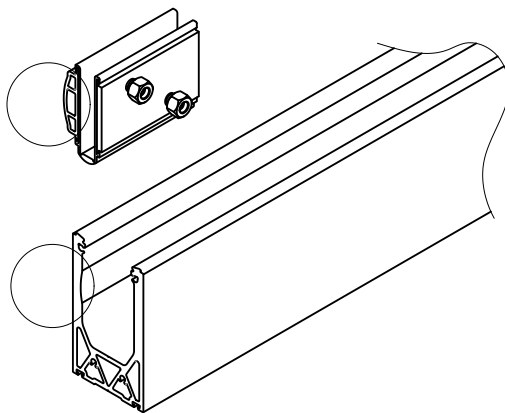

Curved plate on the Glass Grips must be matched to curved surface of the base shoe.

5

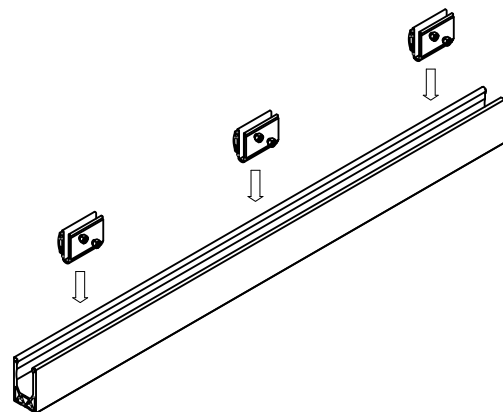

Refer to Engineering Documents for spacing between glass grips. Additional glass grips are available to be ordered separately.

# Installation Instructions

## Top Mount Base Shoe - Aluminum Cladding

SSSM3SHOE10A (10 ft.)  
SSSM3SHOE20A (20 ft.)



6

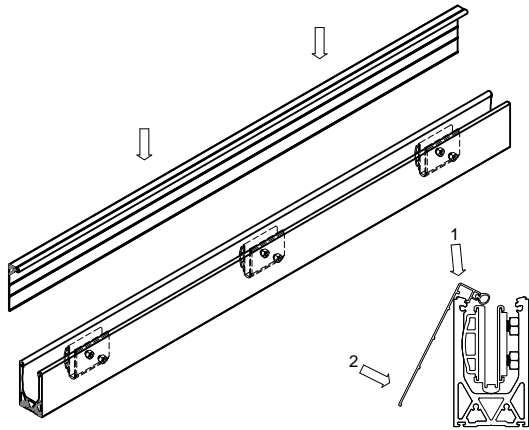

Install one piece of Brushed Anodized Aluminum Cladding on the outside. To do so, just clip it in place.

7

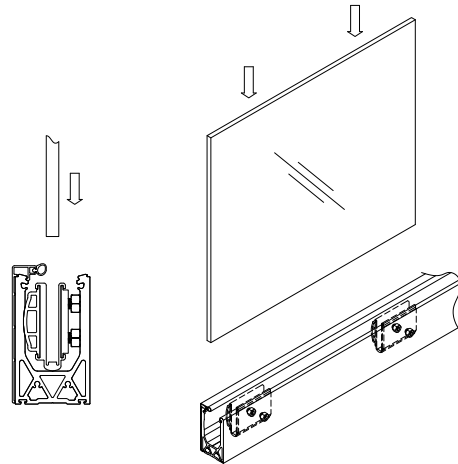

Slide the glass panel(s) into the glass grips.

8

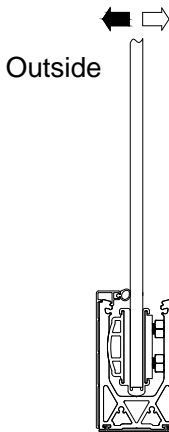
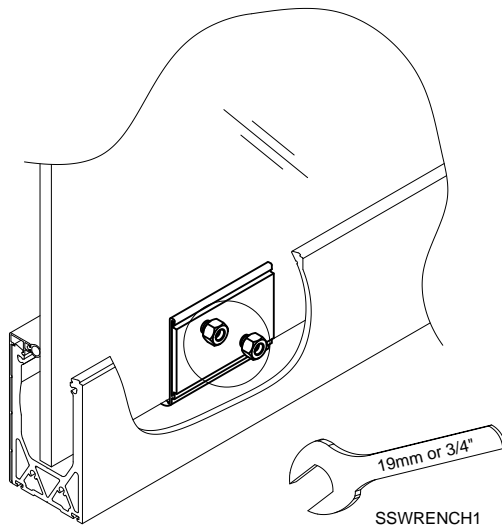

To adjust:  
Loosen upper fastener (turn CCW) and tighten lower (turn CW) to tilt glass outward and vice versa.

Upper fastener  
Lower fastener

9

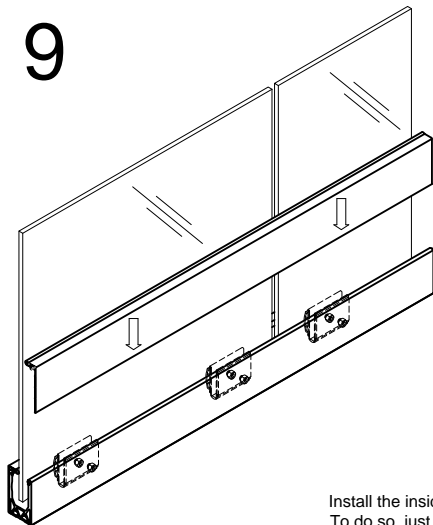

Outside

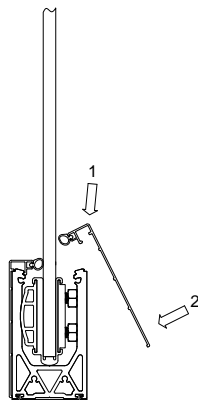

Install the inside Brushed Anodized Aluminum Cladding. To do so, just clip it in place.

10

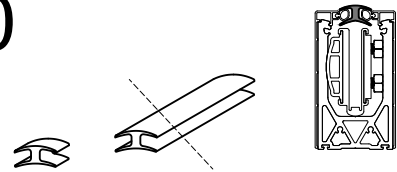

Cut the Gap Filler to match the size of the gap between glass panels and insert between gaskets at glass-to-glass gap.

11

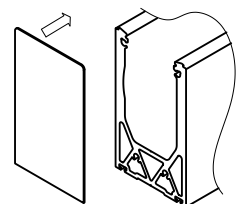

Use adhesive to attach the End Caps.